

Raffaello Series

HIGH PRESSURE HOMOGENIZERS AND PLUNGER PUMPS SINCE 1974



The new
Raffaello Series,
conceived with new modular design,
guarantees high flexibility. It is designed
with reliability in mind for easy
maintenance and installation and for
heavy duty applications. Suitable for CIP
and SIP

MODEL TABLE* | MAXIMUM CAPACITY** | PRESSURE

MODELS	POWER kW	PRESSURE bar	150	200	250	400	600	1.000	1.200	1.500
HA/PA33045	45	CAPACITY l/h	8.500	6.000	5.000	3.000	2.000	1.000	500	500

*Values referring to machines with fixed capacity

**Values referring to products with a max viscosity of 500Cp

TECHNICAL DATA

Plunger number	3
Stroke (mm)	70
Weight (Kg)	1.670
Water consumption (l/h)	200
Lubrication oil quantity (kg)	25
Product inlet/outlet	Socket weld flange \varnothing e52 \varnothing i46 / \varnothing e40 \varnothing i35

Design according to MACHINE DIRECTIVES and the HARMONIZED EUROPEAN STANDARD in force.



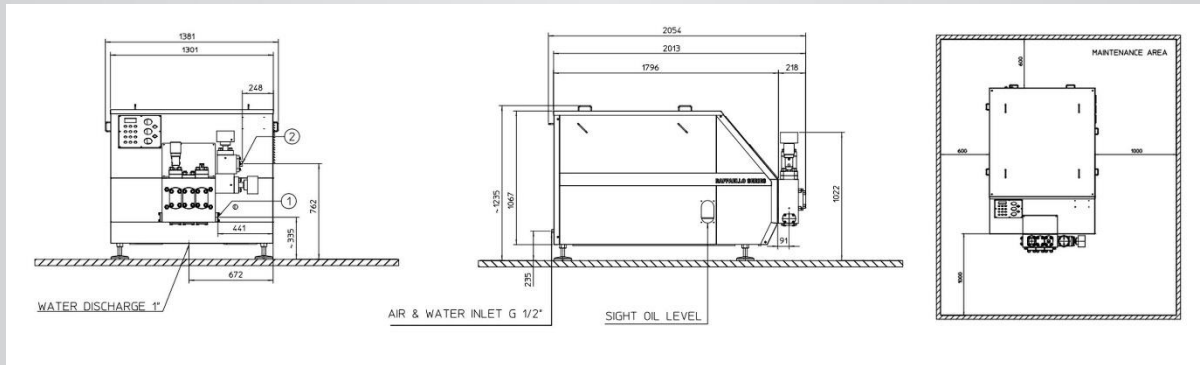

FEATURES

Duplex (SAF2205) monoblock stainless steel compression head of high mechanical and corrosion resistance, self alignment patented plungers chrome coated

Double stage transmission system with pendular gear reducer and trapezoidal belts and pulleys

Homogenizing group with hydro-pneumatic adjustment of the pressure for maximum stability and homogenizing valves in stellite™

Conical valve seat and poppet valves in stellite

Overpressure valve, flow switch alarm on water circuit

Digital pressure transmitter with ceramic membrane

Forced lubrication system with pressure switch, cast iron crankcase with supporting roller bearings

Terminal box and control panel for local/remote control

OPTIONS

Second stage homogenizing group

Superduplex (SAF 2507) Multiblock compression head for pressure >600 bar

Aseptic execution

- Sterile water generator by means of condensed steam generator
- Patent pending sterile water generator by means of microfiltration

3A, EHEDG or PHARMA design

- Low roughness and electropolished wettables
- Certification manual for cGMP

Standard or sharp edge Homogenizing valve with different geometries depending on the type of product

- Tungsten carbide
- Ceramics
- High efficiency Margherita valve

Ball type valve groups

Tungsten carbide valve seats

Pumping plungers

- Tungsten carbide coating
- Integral ceramics

Electric board

- Internal electric board fixed and variable capacity
- Automatic pressure control (PID) by means of PLC

Inlet and outlet connections

- DIN 11851, Tri Clamp, SMS
- High pressure outlet
- Option upon request

Explosion proof design

Sound proof design

Vibration and temperature monitoring and alarm

